

A  
B  
C  
D  
E  
F

1 2 3 4 5 6 7

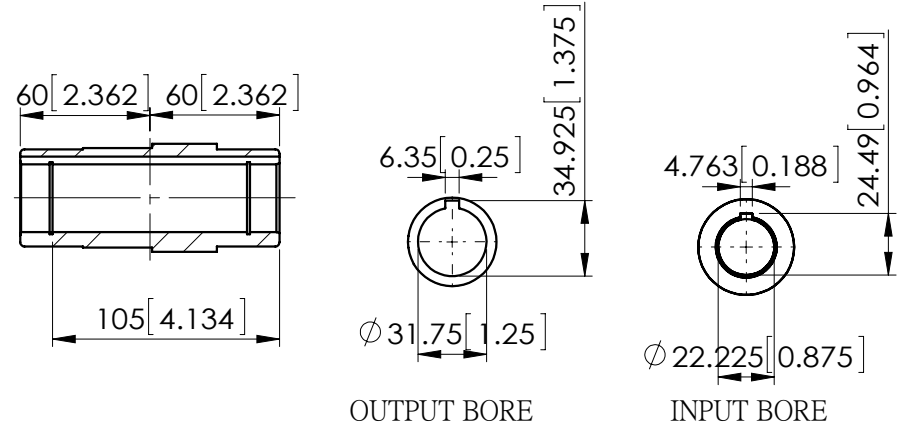
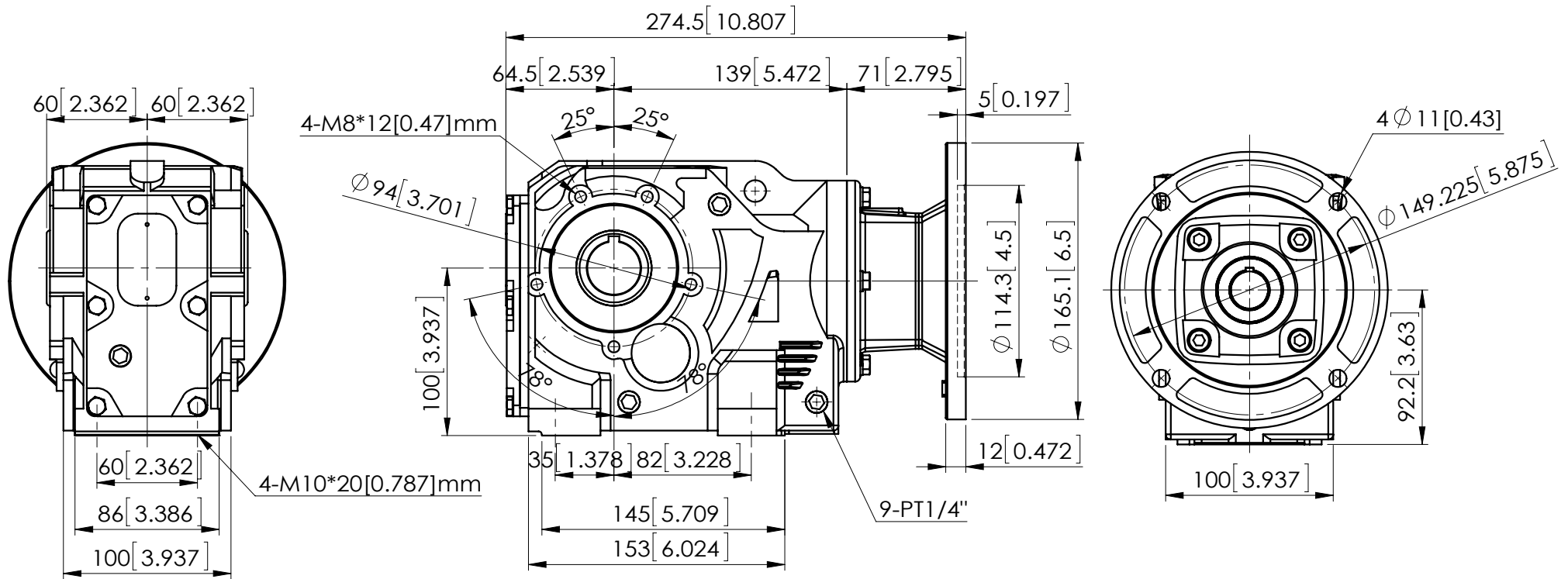

KAN37						
NO.	PART NO.	MATERIAL	PC	RAW MATERIAL	WEIGHT	NOTE
	DWG.	2019.04.18	Y.SP	<b>WORLD WIDE</b>		
	DESN.					
	APPR.					
		DATE	NAME	TITLE	KAN37-143TC	
		SCALE	1:3.5	DWG. NO.	KAN37	REV.

NO.	SECTION	ORIGIN	MODIFICATION	DATE	IN CHARGE

SCABBLE TOLERANCE  
 >0 ± 0.1  
 >6 ± 0.2  
 >30 ± 0.3  
 >120 ± 0.5  
 >315 ± 0.8  
 MACHINING REQUIRED  
 ~ NO-MACHINING  
 ▽ 50S  
 ▽▽ 25S  
 ▽▽▽ 6S  
 ANG. TOLERANCE ± 0.5